

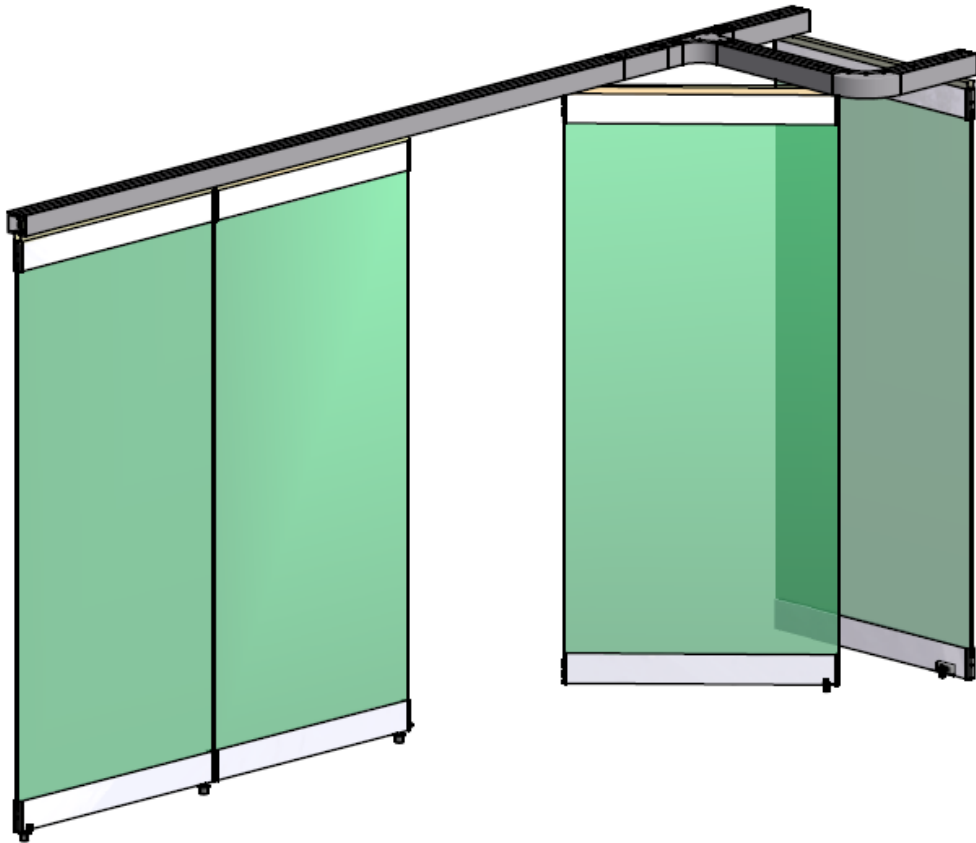

Heavy Duty Sliding And Stacking Wall System (SWS-DR)



Assembly instruction and manual

Contents

1	Safety Notes	1
2	Description of system	3
3	Overview	4
3.1	Examples	4
3.3	System components	6
4	Preparation and procedure	9
5	Fitting the top running track system	9
5.1	Butted connections	9
5.2	Pre-assembling the parking space	10
5.3	Fitting the parking space	10
5.4	Fitting the revision piece	10
5.5	Fitting the running tracks	10
5.6	Final fitting of track system	10
5.7	Running track buffer	11
6	Doors	12
6.1	Typical door variants	12
6.2	Preparation	14
6.3	Glazing of door elements of toughened safety glass	14
6.4	Pre-assembling the sliding door	15
6.5	Fitting the sliding door	16
6.6	Fitting the pivot door	16
6.7	Fixed glazing	16
7	Final tasks	17
8	Adjusting and testing	17
9	Maintenance	18
10	Operation procedure	18

Description of symbols



means "work to be done"



means "important information"



means "additional information"



marks text that has to be read and observed by all means!
Non-observance may cause injury to persons or damage to property!



Residual hazards when operating the **sliding and stacking wall system** (danger analysis).
After the installation of the system there are still some residual hazards for the operation and the use of the **sliding and stacking wall system** that cannot be excluded for constructional reasons:

- there might (manual operation) be the risk of fingers getting jammed between the edges of the door leaves during the closing movement of the door.
- there is the risk of fingers getting jammed between the door leaves or between the door leaves and the wall or other structures when parking the door leaves in the parking space.
- there is the risk of fingers getting jammed between the door leaves or between the door leaves and the wall or other structures during the revolving movement of the utility sliding doors.

Abbreviations:

S: Sliding door
P: Double-action pivot door

1 Safety notes

Use in accordance with intended design purpose

The **sliding and stacking wall system** has been designed for the separation or division of rooms in commercial and private buildings.

The use of the **sliding and stacking wall system** for any other purpose than the design purpose is subject to verification and written approval by GCC.

Any modifications of the product must be approved in writing by GCC.

Suitable areas of application:

The enclosed mounting instructions describe the construction of the **sliding and stacking wall system** as a system with toughened safety glass. For other materials such as timber & Aluminum, the instructions described shall apply in a general sense.

Safety instructions

All mandatory fitting, servicing and repair work should be carried out by competent personnel recommended by GCC.

- Any safety testing needs to be carried out in accordance with the regulations and statutes of the respective state.

- GCC will not accept liability for any injury or damage resulting from unauthorized modifications of the system.

- GCC does not uphold any warranty if the product is used in combination with products by third parties.

For repair and maintenance work only GCC or the competent personnel recommended by GCC may be used.

- With respect to guidelines, standards and state/country-specific regulations, the up-to-date version should be observed.

After project planning but not later than immediately after installation, an analysis of the potential risks associated with the **sliding and stacking wall system** as well as the surrounding area, has to be carried out. Any potential dangers must be eliminated by the organization in charge and if that is not possible, users must be alerted to any residual risks by warning signs.

Planning / calculation

GCC offers support with the planning of the **sliding and stacking wall system**. The customer is obliged to check the design of the system including parking space, number and type of elements, weights, wall connections, auxiliary doors, lock position etc. upon receipt of confirmation of the order and our documents to acknowledge the accuracy of the statement in writing (legally valid). GCC will not assume any liability resulting from inadequate verification or insufficient data delivered by the customer.

Working with safety in mind

Secure the work place against entry by unauthorized persons. Mind the swing area of long system components.

Never work alone when carrying out work with security risks (e.g. installation of the track). Apply safety label to glass panels.

There is a risk of injury through pinching, impact, shearing and catching points! There is a risk of injury through glass breakage!

There is a risk of injury through sharp edges!

There is a risk of injury through freely movable parts during installation!

There is a risk of injury through freely moving parts during installation!

Securing of screws

We recommend to secure all screws with locking agents!

Limit of liability

GCC does not accept any liability for direct or indirect damage or injury if the instructions in this document for the **sliding and stacking wall system** are not followed.

The company reserves the right to introduce, without prior notice, technical modifications for the improvement and further development of the product at any time.

You are welcome to contact our Customer Service for further information.

Transport and Storage

The elements, components etc. of the **sliding and stacking wall system** have not been designed for hard knocks or to withstand the impact from falling from any height.

Do not throw, do not drop!

Storage temperatures below 0°C and above + 80°C can lead to damage of the unit.

For dry rooms only!

Protect from exposure to moisture.

Rules and notes for handling GCC sliding and stacking wall system.

Personnel operating the system must be specially trained and authorized.

Damage to the **sliding and stacking wall systems** does occur from time to time. There are two main causes for this:

- Careless handling of the glass doors when opening and closing
- Vandalism or damage due to attempted break-ins outside the opening hours

Here are some rules to avoid damaging the **sliding and stacking wall system** when opening and closing them:

Please ensure that prior to commissioning the system the running faces of the running tracks have been cleaned with a dry and grease-free cloth over the whole length. Never apply grease or oil to the rollers or the running faces of the running tracks.

2. The floor sockets have to be cleaned once a month, using a vacuum cleaner.
3. With the **Sliding And Stacking Wall System**, the glass elements should always be pushed and turned individually from the starting position to the final position.
4. The door leaf has to be guided by hand during its travel. It is imperative to avoid swinging movements!
5. Please remember that the all-glass **sliding and stacking wall system** move very easily, especially the new ones. For this reason one must avoid the heavy glass elements rolling too fast as it would take considerable force to stop them. Never move the glass elements faster than at a speed that allows you to control them and stop them at any time. Slow down the speed of travel before entering bends or curves.
6. Obviously, the glass elements must never be allowed to impact each other or to hit other hard objects. Carry out careful and regular checks on the movable glass elements for damage. When glass elements are damaged (e.g. deeper scratches etc., but especially any chipping of the glass, even if only slight), the glass must be assessed by an expert, as in such cases, there is a risk of glass breakage and hence damage to property and injury to people.
7. Likewise, bolts and locks should be handled with appropriate care. Do not apply force when operating these items. A drop of oil on the bolts will ensure ease of operation in the longer run.

We do not accept liability for damage, in particular damage caused through wrong handling, unless due to gross negligence or intent on our part. In as much as we are not guilty of intentional contract infringement, any liability for compensation is limited to predictable damage that can be expected to occur in a typical situation. Our liability is governed by statutory regulations where we are guilty of infringing an essential duty under the contract; however, should such a case occur, any liability for compensation is limited to predictable damage that can be expected to occur in a typical situation. In all other cases, any liability for compensation is precluded, irrespective of the legal nature of the respective claim. This applies in particular to claims for compensation based on negligence in contracting or positive breach of contract. The mandatory provisions of the Product Liability Act remain unaffected.

Normally, any faults do not occur suddenly. By letting us know in good time you give us the opportunity to help you and avoid significant costs and trouble.

2 Description of system

2.1 Applications and functions

GCC **sliding and stacking wall system** available for internal applications as well as for some external installations. In accordance with the intended design purpose, components must not be installed and operated for any duties other than those agreed in the contract of sale.

Usually it is technically possible to make changes in the concept and construction of the system, even in the short term, but such changes need to be discussed with the supplier.

The weights of the elements have been considered in the design of the overall construction of the system and an increase in weight is not permitted without confirmation and written approval by the supplier.

2.2 System type GCC-SWS: Sliding and stacking wall system

The concept of the **sliding and stacking wall system** is based on a building block system, which allows orders to be compiled in accordance with the local requirements. It may be possible to carry out changes to the system on site. The **sliding and stacking wall system** elements are currently available in the following types of glass.

10mm toughened safety glass

12mm toughened safety glass

2.3 Sub-structure

The substructure components are to be supplied by the respective glass or metal construction company. Construction details are the responsibility of the metal construction company. The sub-structure must be level over the whole length of the system, the maximum tolerance being ± 2 mm.

Using 3D laser line machine (GCC item no. LS-168R) to check the top track and the sub-structure level is suggested.

The weights of the elements have to be considered in the structural calculations and design both for static and dynamic loading situations. Beyond the stated tolerance, the sub-structure must not be subject to sagging, vibrations or deflection. The total weight of the elements in the stacking space must be taken into account.

In the area of hinged doors no sag of the sub-structure is permitted as this would affect the clearance height and hence the function of these doors.

3 Overview

3.1 Examples

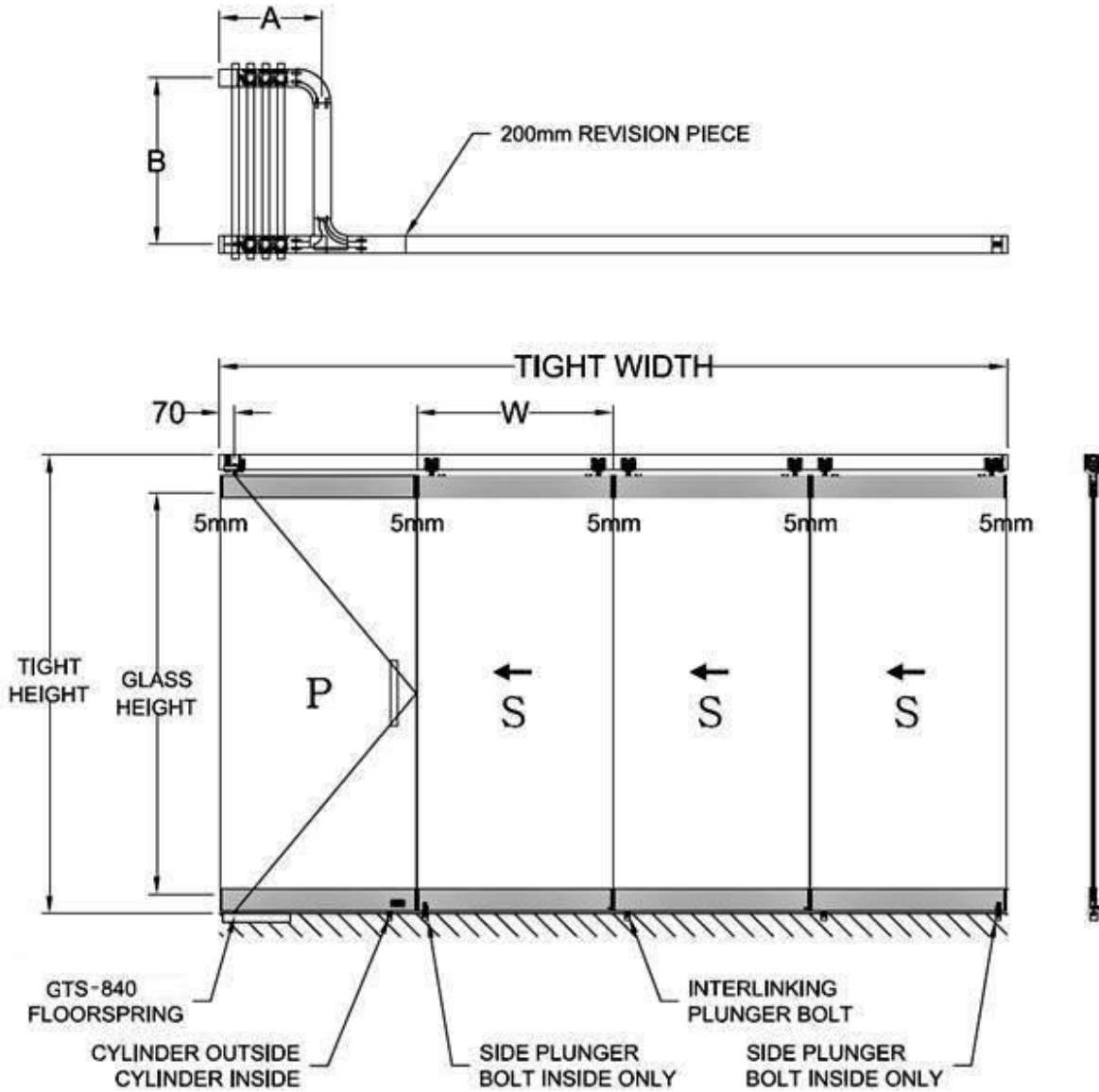

Calculation

T: Tight width

W: Panel's width (Max 1250mm)

H : Tight height (from floor to ceiling – Max 4000mm)

N: Total panel quantity

BG: Bottom Gap (9115 = 10mm)
(GTS-840 = 10mm)
(9150 =10-15mm)

$$W = \{T - (N + 1) \times 5\text{mm}\} / N$$

$$A = (N + 1) \times 70 + 116\text{mm}$$

$$B = W - 130\text{mm}$$

$$\text{GH (Glass High)} = H - 248\text{mm} - \text{BG}$$

Top gap can be 20mm~30mm

The diagram use 22mm top for example.

3.2 Examples Cont

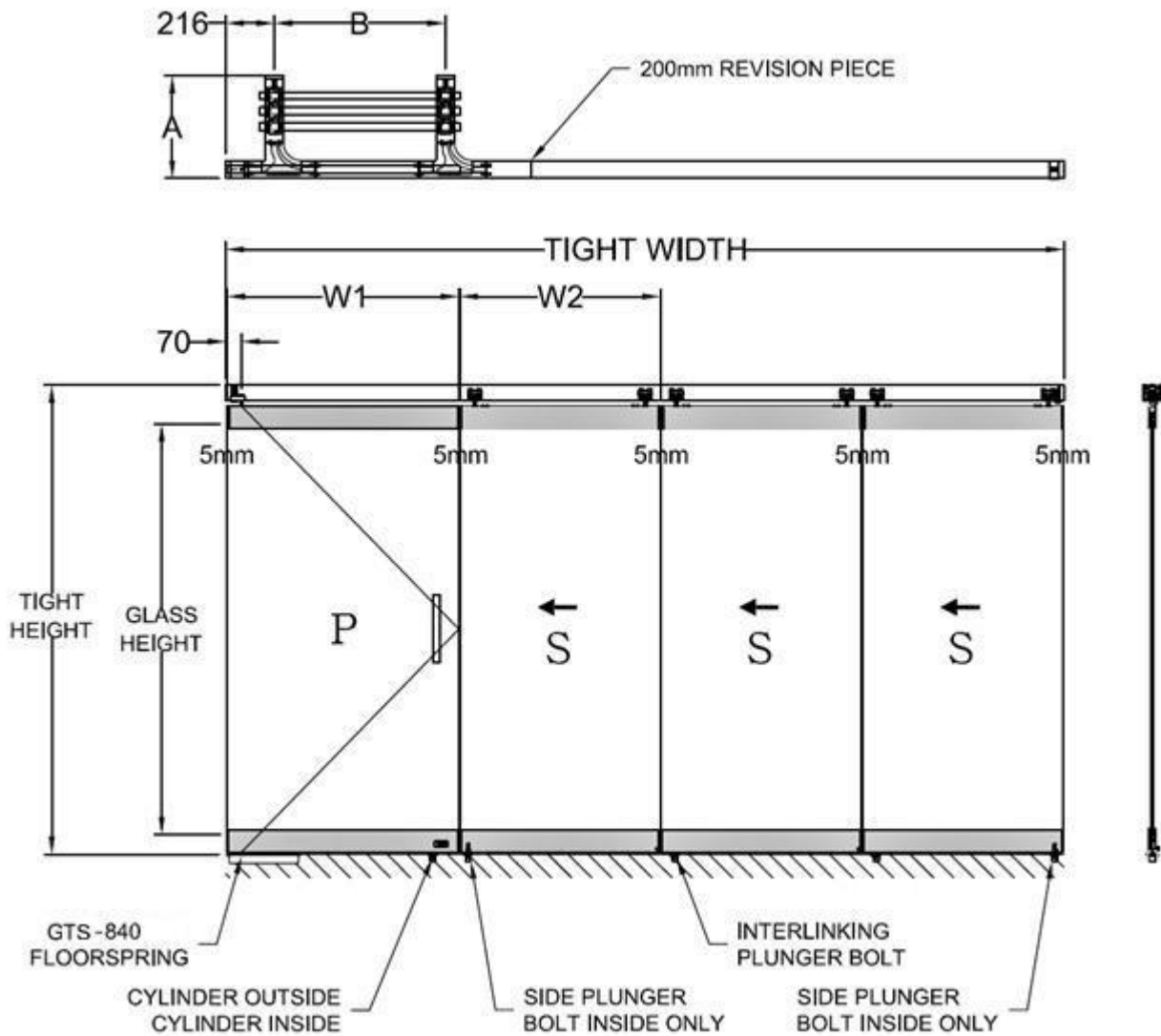

Calculation

T: Tight width

W: Panel's width (Max 1250mm)

H : Tight height (from floor to ceiling – Max 4000mm)

N: Total panel's quantity

BG: Bottom Gap (9115 = 10mm)
(GTS-840 = 10mm)
(9150 = 10-15mm)

$$W1 = \{T - 146 - (N + 1) \times 5\text{mm}\} / N + 146$$

$$W2 = \{T - 146 - (N + 1) \times 5\text{mm}\} / N$$

$$A = (N + 1) \times 70 + 215$$

$$B = W - 130$$

$$\text{GH (Glass High)} = H - 248 - \text{BG}$$

Top gap can be 20mm~30mm

The diagram use 22mm top for example.

3.3 System components

3.31 Running tracks

Material: mill or natural aluminum anodized (Standard)

Running track (application: walk-through area or parking space)

standard length 3000 mm Part No. SWS-80ST

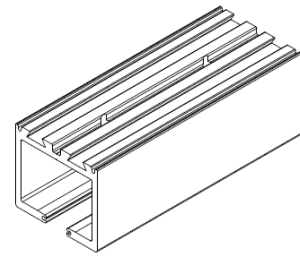

nominal radius 150 mm	90°	Part No. SWS-80RL
Mitred	90°	Part No. SWS-80L-90
Mitred	95°	Part No. SWS-80L-95
Mitred	135°	Part No. SWS-80L-135

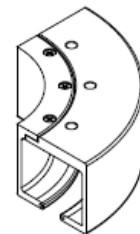

Running track **bend** (application: walk-through area or parking space)
 Running track **branch bend** (application: parking space)

nominal radius 150 mm	(L)90°	Part No. SWS-80RT(L) (SHOWN)
nominal radius 150 mm	(R)90°	Part No. SWS-80RT(R)
Mitred	(L)90°	Part No. SWS-80T(L)
Mitred	(R)90°	Part No. SWS-80T(R)
Mitred	(L)135°	Part No. SWS-80T(L)-135
Mitred	(R)135°	Part No. SWS-80T(R)-135

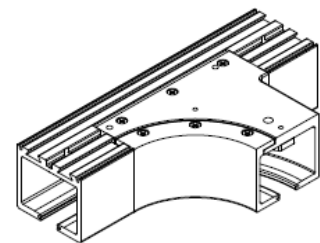

Running Track **Connectors**

Connecting bars (application: all joints except revision piece)

Part No. SWS-80CNB



Connecting pins (application: all joints)

No. SWS-80CNP



3.32 Suspension

Suspension bracket Part No. SWS-80SB

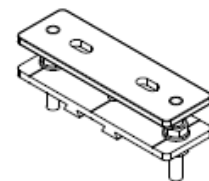

3.33 Door rails

Material: mill or natural aluminum anodized (Standard)

DR102 Door rail (application: top rails & bottom rail with weather seals)

standard length 3000 mm Part No. DR102-30AL

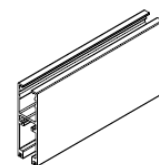

DR101 Door rail (application: bottom rail without weather seals)

standard length 3000 mm Part No. DR101-30AL

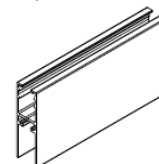

Door rail **inner clamps** (application: clamps glass inside door rails)

200mm – 12mm glass	Part No. IC102-1220
300mm – 12mm glass	Part No. IC102-1230 (SHOWN)
400mm – 12mm glass	Part No. IC102-1240

200mm – 10mm glass	Part No. IC102-1020
300mm – 10mm glass	Part No. IC102-1030
400mm – 10mm glass	Part No. IC102-1040

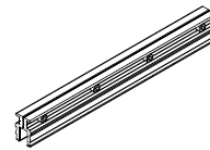

Fixing set – inner clamps	Included
---------------------------	----------



Door Rail end caps

Material: plastic, black

Top Rail & Standard (blank) bottom rail

Part No. EC-102PAA



Bottom rail – to receive DFB-102ST straight flush bolt (female)

Part No. EC-102PAB



Bottom rail – with DFB-102ST straight flush bolt (male)

Part No. EC-102PAC



Fixing set – end caps	Included
-----------------------	----------



3.34 Seals

Door rail seals

10mm Rubber seal – Grey	Part No. RS-1050 G
– Black	Part No. RS-1050 B
15mm Rubber seal – Grey	Part No. RS-1550 G
– Black	Part No. RS-1550 B
20mm Rubber seal – Grey	Part No. RS-2050 G
– Black	Part No. RS-2050 B
25mm Rubber seal – Grey	Part No. RS-2550 G (shown)
– Black	Part No. RS-2550 B
10mm Brush seal – Black	Part No. SQ50S
25mm Brush seal – Black	Part No. SQ50

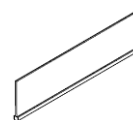

Edge seals

Self adhesive	– Clear	Part No. GB-814
Clip on	– Clear	Part No. PU10BS Part No. PU12BS

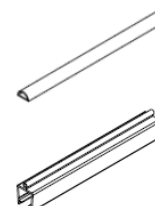

3.35 Roller carriages

Pair

Part No. RH/DR-102

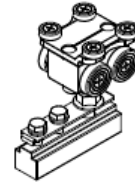

3.36 Track buffer (application: door stops)

Part No. SWS-80EST



3.37 Pivots (application: access door)

Top pivot set

Part No. SWS-80TC/LP

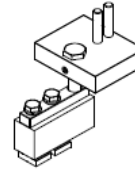

Bottom pivot strap

Part No. 9123

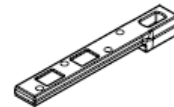

Bottom pivot arm

Part No. ML-100

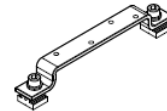

Bottom free bearing pivot

Part No. 9115

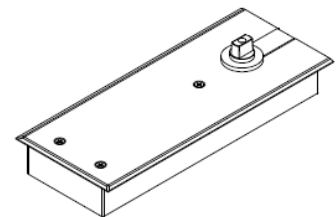
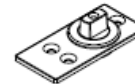

Floor Spring (<1200mm,<100kg)

Part No. GTS-840

3.38 Locks (application: Securing/locating door panels)

Security lock with double cylinder (application: pivot panel)

To suit DR101 door rail

Part No. DRL-5025A

To suit DR102 door rail

Part No. DRL-5025B (**SHOWN**)

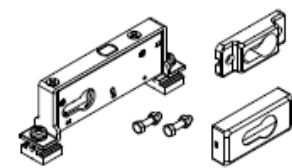

Side plunger bolt (application: first sliding & end panels)

To suit DR101/102 door rail

Part No. DFB-102S



Interlinking plunger bolt (application: intermediate panels)

To suit DR101/102 door rail

Part No. DFB-102ST

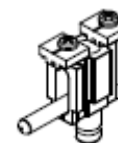

Floor Socket

Part No. 9147/DR



4 Preparation and procedure



We recommend to follow strictly the recommended steps: (Take note of system drawing!)

1. The sub-structure (supplied by others, not GCC) has to be in place unless the system is to be fitted directly to the ceiling.
2. Where this has been specified, the floor construction needs to be completed including any boxes for double-action doors.
3. Fit the top track system (see chapter 5) including pre-fitting of parking space.



The respective turning axis must be exactly below the top pivot bearing which is to be fitted afterwards.

4. Pre-assemble and fit the sliding doors (see sections 7.4 and 7.5).

5 Fitting the top running track system



Danger of injury

- through falling from ladders and scaffoldings
- from falling components or tools
- within the turning radius of long components

- ⇒ Never leave any components or tools on ladders or scaffoldings. These may fall down and cause serious injury.
- ⇒ Please ensure that ladders and scaffoldings are safe and secured against collapse.
- ⇒ Do not move or fit large or heavy components by yourself.

5.1 Butted connections



Sawn cuts have to be precise at right angles (± 0.2 mm) and even.

Where sawing is required:

- edges should be de-burred.



Do not chamfer the area of the running and guide rollers

- Clean the running track before you put any roller hanger into the track.
- Use the connecting bars (1) (ID: SWS-80CNB) & connecting pins (2) (ID: SWS-80CNP) as connectors.
- Fit the elements without any gaps.

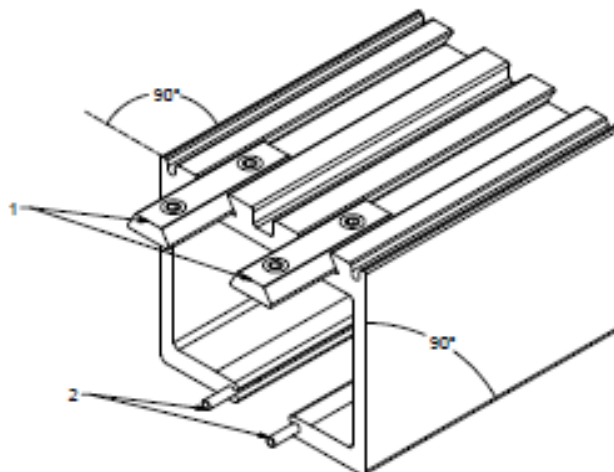

5.2 Pre-assembling the parking space



The connecting faces must be fitted without any gap, i.e. butting up to each other!

1. Spread out all parts of the parking space tracks with accessories on a level surface and compare with the system layout drawing.
2. Use the connecting pieces to screw the individual tracks together.



For ceiling mounting we recommend the following components:

- M8 Hexagonal bolts of strength class 8.8 with internal steel thread, inserted at least 6 mm deep.
- Dowel screws with thread (stud bolt) M8 and nut.
- SWS-80SB Adjustable Suspension Bracket (once assembled, M8 threads to be welded or secured with locking agent).

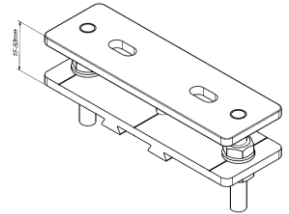

5.3 Fitting the parking space



Align horizontally, using a spirit level and levelling device (GCC item no. LS-168R).

- Screw the pre-assembled parking space components to the substructure.
Use the following in accordance with the system drawing:
- Bends, branches and (fitting pieces) pre-assembled in the factory
 - Hexagonal bolts M8 with

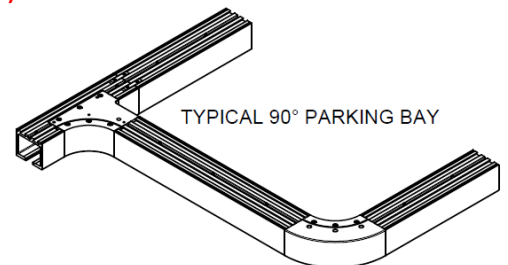

The spacing between fixings in the parking area must not be greater than 140 mm.

5.4 Fitting the revision piece



The revision piece may be required later for any servicing of the sliding doors.

This component is always fitted directly to the branch!



Only use the connecting pins (ID: SWS-80CNP) for fitting.
DO NOT USE THE CONNECTING BARS (ID: SWS-80CNB) UNLESS THEY CAN BE ACCESSED I.E. VIA THE SPACE PROVIDED BY THE USE OF SUSPENSION BRACKETS (ID: SWS-80SB)

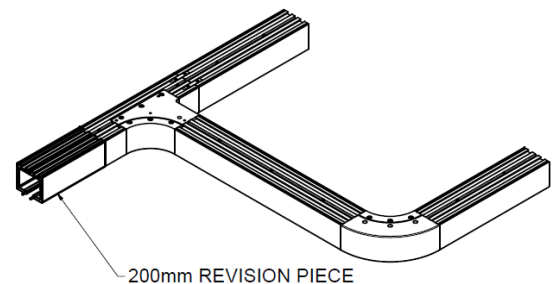

5.5 Fitting the running tracks



Align horizontally, using a spirit level and levelling device (GCC item no. LS-168R)..

Screw the running tracks and any bend tracks to the substructure in accordance with the system drawing.

5.6 Final fitting of track system



Check the butt joints of the tracks. There must not be any discernable steps in the running faces.
Use abrasive paper to smooth out the track joints very lightly. This will help to achieve a quiet operation!

Pivot door fittings

(where provided in the system drawing)

Fit the top pivot bearing and the bottom pivot bearing exactly vertically aligned in preparation for the hinged door.



Ensure there are NO fixings or obstructions in the track directly above the axis of the pivot

Several different arrangements are possible, depending on the layout of the system. Take note of the system drawing.

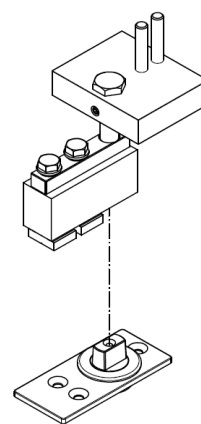

5.7 Running track buffer

Fit the running track buffers (ID: SWS-80EST) in order to prevent any damage while handling the **sliding and stacking wall system** elements.



The buffer is to be positioned with the black rubber buffer facing the roller carriage .

The exact position of the running track buffers is to be determined at a later date.

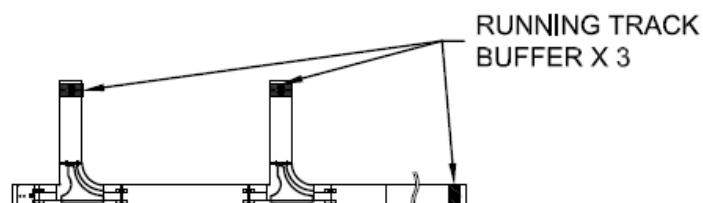
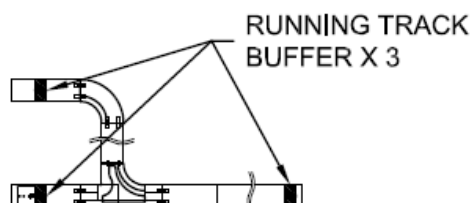
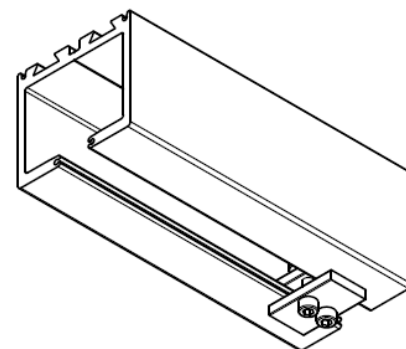
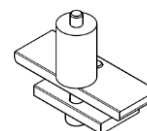

6 Doors

6.1 Typical door variants

Sliding panel - Intermediate

Includes;

- Top rail (DR102) <1250mm
- Bottom rail (DR 101 – **NO** bottom seal) <1250mm
- 2-3 x Inner clamps each rail (IC102-1220/30/40)
- 2 x End caps – blank (EC-102PAA)
- 1 x End cap – hole (EC-102PAB)
- 1 x End cap – slotted (EC-102PAC)
- 1 x Interlinking plunger bolt (DFB-102ST)
- 1 x Floor socket (9147/DR)
- 1 x Set of roller cars (RH/DR-102)

Optional;

- Bottom rail (DR 102 – suits bottom seal)
- 2 x 10mm rubber seal (RS-1050) <1250mm
- 10,15,20 & 25mm rubber seals in grey or black
- 10 & 25mm brush seals in black
- Adhesive edge seal (**GCC item no. PT1012**)
- Clip on edge seal (**GCC item no. PU10/12BS or P10/12HJ**)
- Inner clamps for 10mm glass

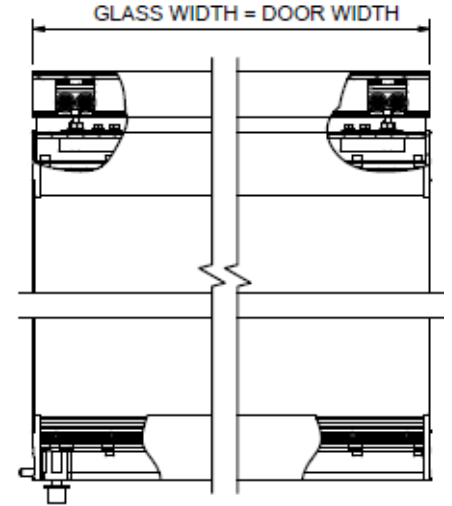
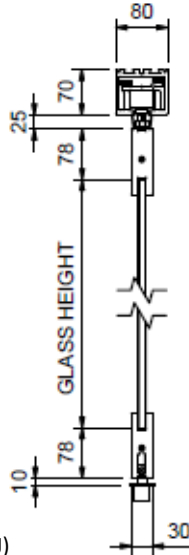

Sliding panel - End

Includes;

- Top rail (DR102) <1250mm
- Bottom rail (DR 101 – **NO** bottom seal) <1250mm
- 2-3 x Inner clamps each rail (IC102-1220/30/40)
- 2 x 25mm rubber seal (RS-2550 G) <1250mm
- 3 x End caps – blank (EC-102PAA)
- 1 x End cap – slotted (EC-102PAC)
- 1 x Interlinking plunger bolt (DFB-102ST)
- 1 x Side plunger bolt (DFB-102S)
- 2 x Floor sockets (9147/DR)
- 1 x Set of roller cars (RH/DR-102)

Optional;

- Bottom rail (DR 102 – suits bottom seal)
- 2 x 10mm rubber seal (RS-1050) <1250mm
- 10,15,20 & 25mm rubber seals in grey or black
- 10 & 25mm brush seals in black
- Adhesive edge seal (**GCC item no. PT1012**)
- Clip on edge seal (**GCC item no. PU10/12BS or P10/12HJ**)
- Inner clamps for 10mm glass

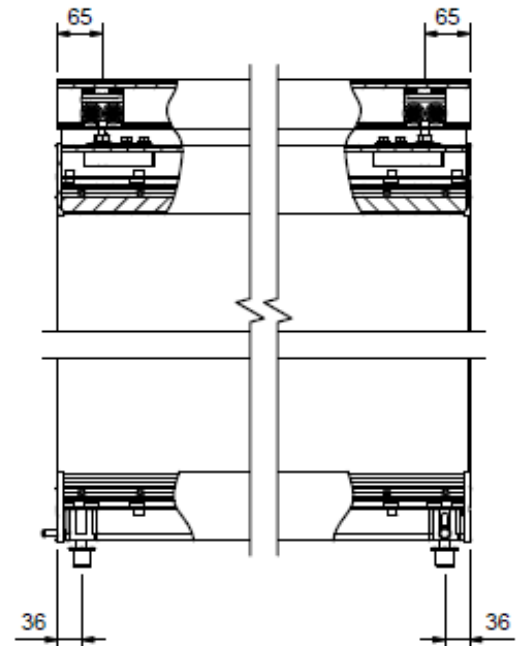
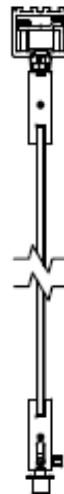

Sliding panel - First

Includes;

- Top rail (DR102) <1250mm
- Bottom rail (DR 101 – **NO** bottom seal) <1250mm
- 2-3 x Inner clamps each rail (IC102-1220/30/40)
- 2 x 25mm rubber seal (RS-2550 G) <1250mm
- 3 x End caps – blank (EC-102PAA)
- 1 x End cap – hole (EC-102PAB)
- 1 x Side plunger bolt (DFB-102S)
- 1 x Floor sockets (9147/DR)
- 1 x Set of roller cars (RH/DR-102)

Optional;

- Bottom rail (DR 102 – suits bottom seal)
- 2 x 10mm rubber seal (RS-1050) <1250mm
- 10,15,20 & 25mm rubber seals in grey or black
- 10 & 25mm brush seals in black
- Adhesive edge seal (**GCC item no. PT1012**)
- Clip on edge seal (**GCC item no. PU10/12BS or P10/12HJ**)
- Inner clamps for 10mm glass

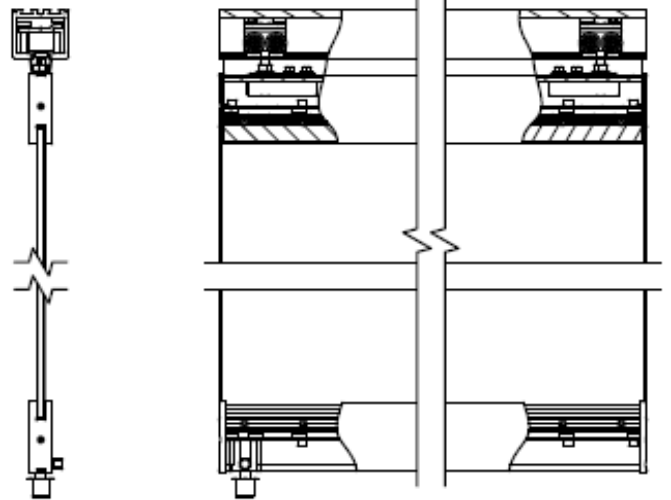

Pivot panel

Includes;

- Top rail (DR102) <1250mm
- Bottom rail (DR 101 – **NO** bottom seal) <1250mm
- 2-3 x Inner clamps each rail (IC102-1220/30/40)
- 2 x 25mm rubber seal (RS-2550 G) <1250mm
- 4 x End caps – blank (EC-102PAA)
- 1 x Security lock with double cylinder (DRL-5025A)
- 1 x Floor socket (9147/DR)
- 1 x Set of roller cars (RH/DR-102)
- 1 x Bottom pivot strap (9123)
- 1 x Bottom pivot arm (ML-100)
- Bottom free bearing pivot (MP26-1)

Optional;

- Bottom rail (DR 102 – suits bottom seal)
- 2 x 10mm rubber seal (RS-1050) <1250mm
- 10,15,20 & 25mm rubber seals in grey or black
- 10 & 25mm brush seals in black
- Adhesive edge seal (**GCC item no. PT1012**)
- Clip on edge seal (**GCC item no. PU10/12BS or P10/12HJ**)
- Cylinder & snib for security lock.
- Hydraulic floor spring (**GCC item no. GTS-840**)
- Centre patch lock
- Door handle
- Inner clamps for 10mm glass

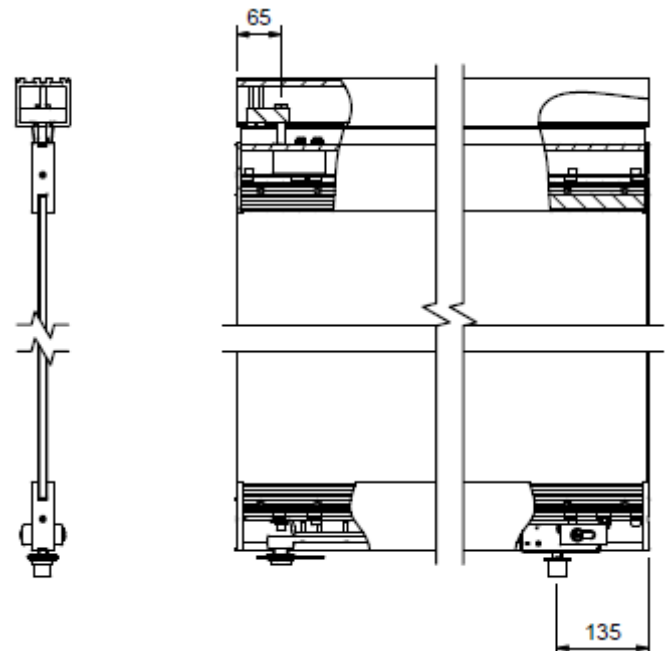

6.2 Preparation



- Clean the running tracks after you fixed it and before you put the roller hangers into the top running track.
- Do not lubricate the running tracks.

Assign the rail profiles to suit the respective door widths. These may vary. Prepare in accordance with the system layout drawing.

6.3 Glazing the door elements



The glass is 10 mm wider than the rail profile. The glass should project evenly by 5 mm on both sides.



- Do not use any other screws for the inner clamps than those supplied in the delivery.
- Avoid scratching the glass pane or the rail profile, therefore it is important to keep the protective plastic & cardboard covers on as long as possible & to work with care.

1. Place the glass pane flat onto suitable fitting trestles with a clean soft surface.
2. Clean the edges of the glass with methylated spirits.
3. Position the inner clamps fully onto the edge of the glass 5mm in from each edge (you can use an end cap as a guide)
The maximum distance between inner clamps is to be no greater than 100mm
4. Tighten each screws (1) at the on the inner clamps with **12~15 Nm and do it levelly.**
5. Slide the rail profile over the inner clamps until it is level at either side & lightly tighten holding screws (2) against the inner clamps.
6. Screw the centring screws (3) between the inner clamp & rail until the counter sink begins. **(do not over tighten)**
Do not confuse the centring screws with the similar looking end cap screws. Centring screws are slightly longer & narrower.
7. Fit the relevant end cap according to the locking type or lack thereof.
8. Carry out another final check to verify the torque on all screws.

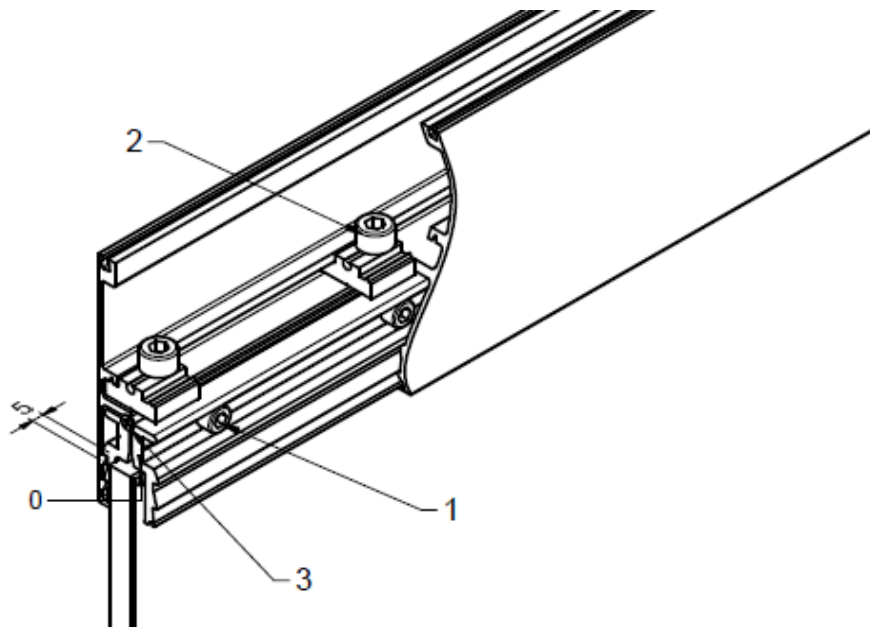

6.4 Pre-assembling the sliding door



- For safety reasons and in view of the weight of the **sliding and stacking wall system** elements, all fittings should be fitted with the unit lying flat.
- The sliding door rails will come mostly pre assembled. You will only be required to attach the roller carriages which will be initially screwed in to a height of approximately 33mm between the top of the rail & underside of the carriage block. Ensure the lead carriage is positioned with its guide wheels on the side of the parking bay & the bottom rail is correctly positioned per the system drawing.

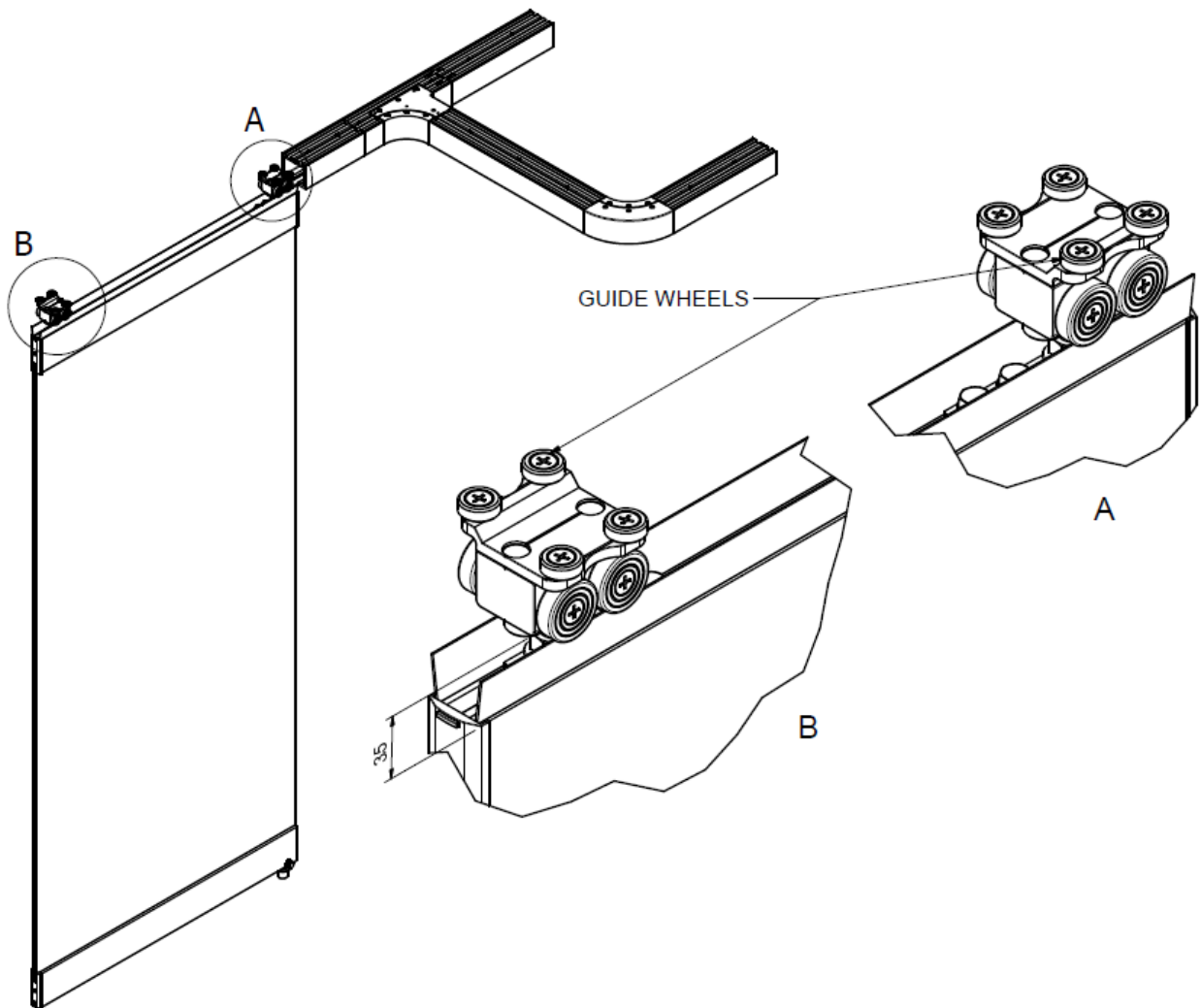

6.5 Fitting the sliding door



Danger of inquiry

- through falling from ladders and scaffoldings
- from heavy components



Please ensure that ladders and scaffoldings are safe and secured against falling over.



Secure the doors against falling over.



Do not move or fit large or heavy components by yourself.



Never place the door directly onto the floor, always rest on temporary supports (e.g. timber sections or plastic parts).



Ensure the rollers are still in the correct position before hanging the door.

1. Remove the revision piece.
2. Clean the top running track before inserting in the roller carriage.
3. Insert the roller carriage into the running track.
4. Replace the revision piece once all doors have been fitted.
5. **Do not tighten the security grub screw until the installation is complete & the doors are adjusted correctly.**



6.6 Fitting a pivot door



The exact position of the turning axis of the respective door should always be determined from the top bearing. This means that the floor-mounted door closer or the bottom pivot bearing needs to be fitted in exact vertical alignment underneath the top pivot bearing.



Make sure to maintain the distances from the pivot bearing to the edge of the door (65 mm) and from the pivot bearing to the wall (70 mm).

1. Loosen the grub screw securing the pivot pin so as the pin can be lifted up & down.
2. Carefully lift the door into position locating the Bottom pivot strap over the pivot bearing or the floor-mounted door closer & the locking side on a 10mm packer.
3. Lift the pivot pin & manoeuvre the door so as the top pivot bearing is directly below it then lower the pivot pin into the bearing.
4. **Retighten the grub screw (important). This will stop the pivot pin from lifting over time.**



6.7 Fitting a fixed panel

Fixed glazing is fitted in the same way as a pivot door but with pivot sets both sides of the fixed panel.

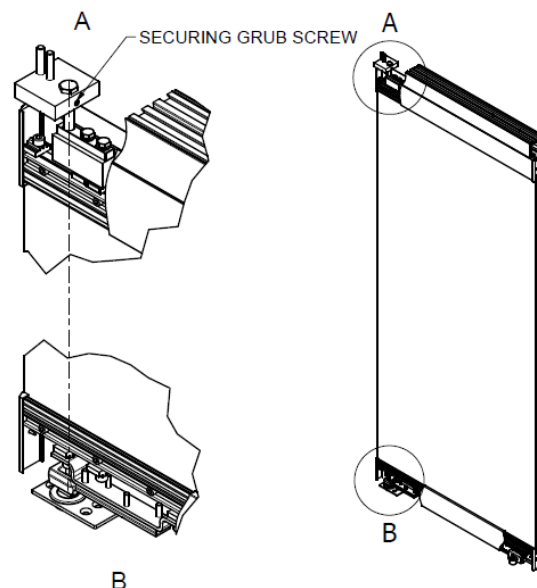

7 Final tasks

1. Fit the floor sockets being careful they are centred directly in line with the locking pin..
2. Slide the door rail seals in to place & trim to size.
3. Replace the revision piece once all doors have been fitted.
4. **Once the doors are adjusted & working correctly, and all floor sockets are installed correctly too.**
Tighten the security grub screw on all roller carriages, this will prevent the doors from lowering over time.
5. Remove all plastic wrapping.
6. Clean system & worksite – ensuring no debris is left that can obstruct the operation of the doors.

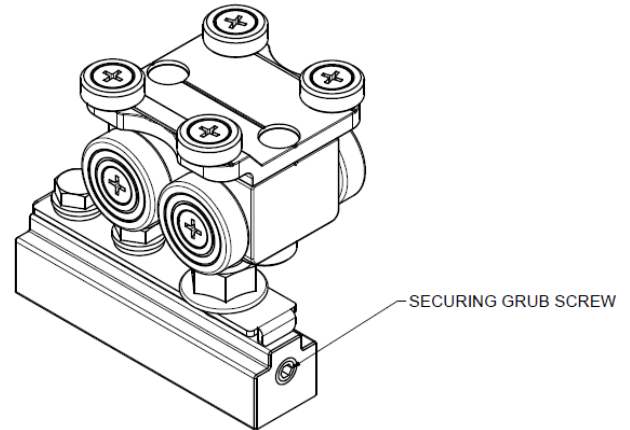

8 Adjusting & Testing

Please check and, where necessary, adjust the following items before taking the system into operation:

- Check all screws and counter nuts for tight fitting.

Ease of operation:

- Gap between the upper edge of the sliding door and the running track to be at least 3 mm
- Gap between the lower edge of the sliding door and the floor to be at least 3 mm, max. 10 mm

Alignment:

- The glass panes should form one homogenous area and not be at angles to each other.

Running track:

- Must be clean: free from dust, building debris, chips etc.
- The running track joints must not be offset, have no gap, coupling pieces in place
- Adequate fixing of the running track to the ceiling or other substrate
- Running track aligned horizontally



In particular after work has been done to the running track, such as drilling, machining etc., the running track must be cleaned very thoroughly.

Floor Sockets:

- Vertically aligned with the lock bolts
- Free from dirt
- Adequately fixed to the floor

Hinged door:

- The max. distance of 10 mm between the wall and the door has been maintained
- Pivot point axis pivot bearing / outside edge NSK = 65-120 mm
- Locking operation is easy
- Turning axis is true vertical
- Door closer fully made good and fixed firmly
- Bottom pivot bearing flush with finished floor level
- Top pivot turning seating firmly

Sliding door:

- Easy to operate (no bumping)
- Sliding panels readily stay in any position (no slope)
- Locks / bolting mechanisms work smoothly.
- Carriage well positioned (does not bind in bends/curves)

Glazing:

- Clamping screws min. 12 N/m, max 15 N/m

General:

- End caps
- All screws seating firmly and secured
- Visual checks (scratches, upright, panels not suspended at different heights)

9 Maintenance

Generally, the system is maintenance free; however, we recommend that the system be inspected at regular intervals to check for excessive wear or soiling.

The interval between maintenance inspections depends on local conditions and how often the system is used. It is possible that air currents (draughts) through the seals, gaps and joins can lead to accumulations of dust.

10 Operation procedure

Opening Doors:

1. Unlock the pivot door & open to 90°.
2. Using your hand, lift the side plunger bolt on the first sliding door to the fully raised position.
3. Using one hand carefully push the door from the edge farthest from the parking bay, keeping consistent momentum until the door sits parallel to the pivot door (approx 70mm away).
4. Using your hand, lift the interlinking plunger bolt on the intermediate sliding door to the fully raised position, keeping the pressure from your hand close to the end cap.
5. Using one hand carefully push the door from the edge farthest from the parking bay, keeping consistent momentum until the door sits parallel to the pivot door (approx 70mm away).
6. Repeat steps 4 & 5 for the remaining doors.

Closing Doors:

1. Using one hand carefully pull the first door from the edge under the main line of track, keeping consistent momentum until the door is completely out of the parking bay.
2. Bring the door carefully to its closed position push the side/interlinking plunger bolt to the fully lowered position.
3. Repeat steps 1 & 2 for the remaining sliding doors.
4. Once all sliding doors are in position & locked, close the pivot door & lock.

